

Digital-Panel-Mounted Display

GTA 0420



Specification:

Input signal:	4 ... 20 mA
Maximum input signal:	25 mA permanent (40 mA short duration)
Display range:	<input type="checkbox"/> 0 ... 1000 <input type="checkbox"/> 0 ... 1999 <input type="checkbox"/> ± 500 <input type="checkbox"/> _____
Decimal point:	can be set at any position by means of soldering jumpers.
Voltage load:	ca. 4.7V (standard connection with wrong-polarity protection) ca. 3.5V (for option: without wrong-polarity protection)
Accuracy: (typ.)	±0.1% ±1 digit
Temperature coefficient:	100 ppm / K
Scanning rate:	3 measurements per second
Display:	3½-digit LCD, 12.7 mm high
Operating temperature:	0 to 50 °C
Atmospheric humidity:	< 85 % r.h. (non-condensing)
Storage temperature:	-20 to 80 °C
Dimension:	38 x 76 x 22 mm (H x W x D)
Panel-cutout:	36 ^{+0.5} x 73.2 ^{+0.5} mm (H x W)
Panel thickness:	max. 9.5 mm
EMC:	The device corresponds to the essential protection ratings established in the Regulations of the Council for the Approximation of Legislation for the member countries regarding electromagnetic compatibility (89/336/EWG). Additional fault: <1%



Safety instructions:

This device has been designed and tested in accordance with the safety regulations for electronic devices.

However, its trouble-free operation and reliability cannot be guaranteed unless the standard safety measures and special safety advises given in this manual will be adhered to when using the device.

1. Trouble-free operation and reliability of the device can only be guaranteed if the device is not subjected to any other climatic conditions than those stated under "Specification".
If the device is transported from a cold to a warm environment condensation may cause in a failure of the function. In such a case make sure the device temperature has adjusted to the ambient temperature before trying a new start-up.
2. General instructions and safety regulations for electric, light and heavy current plants, including domestic safety regulations (e.g. VDE), have to be observed.
3. If device is to be connected to other devices (e.g. via PC) the circuitry has to be designed most carefully. Internal connection in third party devices (e.g. connection GND and earth) may result in not-permissible voltages impairing or destroying the device or another device connected.
4. If there is a risk whatsoever involved in running it, the device has to be switched off immediately and to be marked accordingly to avoid re-starting.
Operator safety may be a risk if:
 - there is visible damage to the device
 - the device is not working as specified
 - the device has been stored under unsuitable conditions for a longer time.
 In case of doubt, please return device to manufacturer for repair or maintenance.
5. **Warning:** do not use these product as safety or emergency stop devices, or in any other application where failure of the product could result in personal injury.
Failure to comply with these instructions could result in death or serious injury.

Selection of decimal point:

The desired decimal point can be selected by connecting the referring jumper contacts (e.g. by soldering).

(Example for measuring range of 0 to 1000)

soldering jumper "1" = DP1, display value = 100.0

soldering jumper "2" = DP2, display value = 10.00

soldering jumper "3" = DP3, display value = 1.000

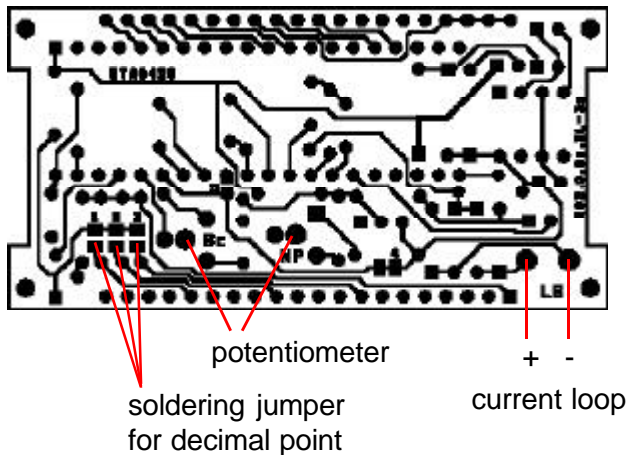

Connection diagram:

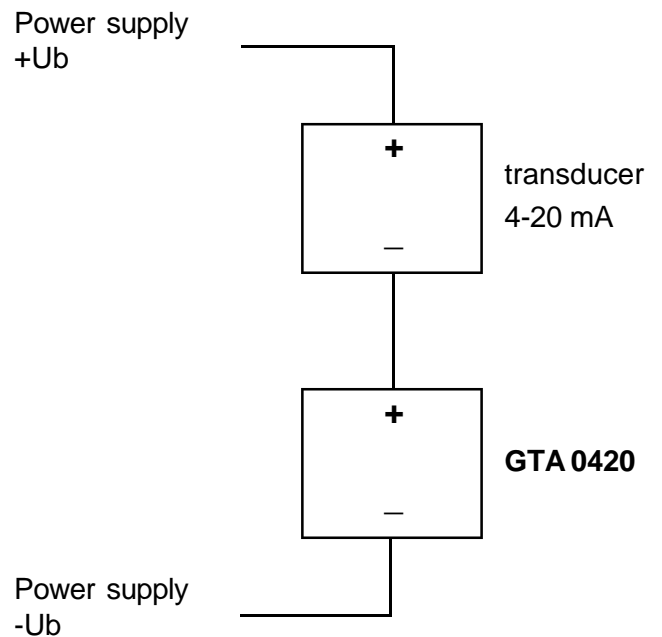

Connecting and Operating Instructions:

1. Assignment:

The standard device has a wrong-polarity protection, i.e. when connecting the device, polarity needs not to be observed.

Devices with option 'No wrong-polarity protection' it is absolutely necessary to connect the device according to the polarity. Please refer to the connection diagram.

2. Possibility of adjusting the displayed values:

The device is adjusted theoretically ex works. By means of the 2 potentiometers the device can be adjusted to Your needs.

NP - Offset

Sc - Scale

3. Check the maximum input current. Overload can destroy the device.

4. Do not operate the module above the specified operating temperature.